

Relative clause structure and projecting movement: Insights from inverse case attraction in Moksha Mordvin

Mariia Privizentseva

(Universität Leipzig, *mprivizentseva@uni-leipzig.de*)

1 Introduction

- Inverse case attraction (ICA) is a phenomenon under which the head of a postnominal relative clause bears case assigned to a relativized element inside the relative clause.

(1) [head- α [CP relative.pronoun- α ... predicate_{[case: α]] ... predicate_[case: β]] ...]}

(2) GEN ← DAT

Jalga-z'ə-n'd'i [kona-n'd'i t'aš-n'ə-n'] mon n'ej-sa kurək.
 friend-1SG.POSS.SG-DAT which-DAT write-FREQ-PST.1SG I[NOM] see-NPST.3SG.O.1SG.S soon
 'I will soon see my friend to whom I have been writing.'

(3) Mon n'ej-sa kurək jalga-z'ə-n'/*n'd'i.
 I see-NPST.3SG.O.1SG.S soon friend-1SG.POSS.SG-GEN/*DAT
 'I will see soon my friend.'

- In this talk, I will argue that (i) **ICA relatives are externally-headed** and (ii) **ICA is derived by raising structure**.

- This implies that raising derivation must be part of natural language syntax (see Schachter (1973), Vergnaud (1974), Kayne (1994), Sauerland (1998, 2003), Bianchi (1999, 2000), Bhatt (2002), De Vries (2002), Donati & Cecchetto (2011), and Sportiche (2017)). I further suggest that it co-exists with the head-external generation.

- After this, I will review existing approaches to the syntax of raising and suggest that it is best derived by **projecting movement of the head noun**, which in turn follows from projection by selection approach to labeling (see Chomsky (1995), Adger (2003) as well as Stabler (1997)) combined with the possibility of upward search (see Baker (2008), Wurmbbrand (2012), Zeijlstra (2012), Himmelreich (2017), and Bjorkman & Zeijlstra (2019), i.a.).

- Finally, I will turn to a long-standing puzzle of case marking in raising derivation (see Borsley (1997)). I will show that ordering of features allows to derive internal case on raising heads in Moksha and external case in other languages.

- This opens up a novel approach to case overwriting phenomena (see Bejar & Massam (1999)) and once again shows that a language specific fixing of an initially indeterminate order of elementary operations may underlie parametrization (cf. Georgi (2017) and Murphy & Puškar (2018)).

(4) Projecting movement in RCs

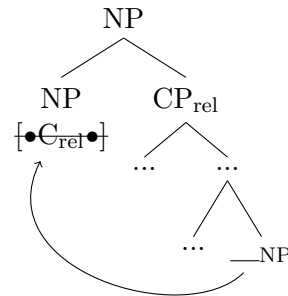

Outline

Section 2: Head of relative with ICA is external.

Section 3: Relatives with ICA are derived by raising.

Section 4: Projecting movement underlies raising structure.

Section 5: Derived left peripheral position follows from second order selection features.

2 ICA and typology of relative clauses

2.1 Background

- Virtually all major structures of relative clauses were assigned to relative clauses with ICA.

1. Relative clauses with ICA are a sub-type of correlative clauses with a linearly reversed order of the relative pronoun and the head noun (see Pittner (1995), Bhatt (2005), Georgi & Salzmänn (2017) and also Bianchi (1999, 2000)).

(5) $[_{CP} \text{ head-}\alpha \text{ relative.pronoun-}\alpha \dots \text{ case.assigner}_{[case: \alpha]} \dots]$, $[_{MC} \dots \text{ case.assigner}_{[case: \beta]} \text{ pronoun-}\beta \dots]$

2. Relative clauses with ICA are internally-headed, but not correlatives (see, e.g., Abramovitz (2021)).

(6) $[_{MC} [_{DP} D \dots [_{CP} \text{ head-}\alpha \text{ relative.pronoun-}\alpha \dots \text{ case.assigner}_{[case: \alpha]} \dots]] \dots \text{ case.assigner}_{[case: \beta]}]$

3. Relative clauses with ICA are externally-headed (see Deal (2016)).

(7) $[_{MC} [_{DP} \dots \text{ head-}\alpha, [_{CP} \text{ relative.pronoun-}\alpha \dots \text{ case.assigner}_{[case: \alpha]} \dots],] \dots \text{ case.assigner}_{[case: \beta]}]$

Claim: Relative clauses with ICA are best analyzed as externally-headed relative clauses.

2.2 Interpretation

- Since Grosu & Landman (1998) and Grosu (2002), three interpretations of relative clauses are standardly identified: appositive, restrictive, and maximalizing.
- Interpretations differ in whether the meaning of a noun phrase with a relative clause is determined inside or outside of the relative CP.
 - Appositive interpretation: Reference of the noun phrase is fully determined outside of the relative CP.
 - Restrictive interpretation: Reference of the noun phrase is determined jointly by a material in the relative CP and a material in the main clause.
 - Maximalizing interpretation: Reference is fully determined inside the relative CP.
- Cross-linguistically, there seems to be a correlation between syntactic type of the relative clause and the set of possible interpretations.
 - Correlatives can be only maximalizing (see Grosu (2002), Lipták (2009), Brasoveanu (2012), Lin (2020)).
 - Internally-headed relative clauses can be maximalizing or restrictive (see Grosu (2002, 2012), Watanabe (2004); cf. also a recent research by Hanink (2021) and Hucklebridge (2022)), but not appositive (see Lehmann (1984, 278), De Vries (2002, 29), Grosu (2012)).

↪ If relatives with ICA have an appositive interpretation, they must be externally-headed.

- The **appositive interpretation** is possible for relatives with ICA. It can be ensured by parenthetical expression as illustrated in (8).

(8) NOM ← GEN
Rovnaj kaftə pr'istupn'ik-n'ə-n' kona-t'n'ə-n' meždū pročim kunda-z'ən' Pet'ε
straight two criminal-DEF.PL-GEN which-DEF.PL-GEN between others catch-PST.3PL.O.3SG.S Petja[NOM]
vor'gəd'-kšn'ə-s'-t'.
run.away-AVR-PST.3-PL
'Exactly two criminals, who Petja, by the way, caught, were running away.'

- Incompatibility of continuation (9a) indicates that the head noun is interpreted in the matrix clause and the reference of the noun phrase that contains a relative clause is fully determined there; that is, the relative clause is appositive.

- (9) a. #Kolmæ-c'ə pr'istupn'ik-s' vor'gəd'-kšn'ə-s' no Pet'ε iz'-əz'ə
 three-ORD criminal-DEF.SG[NOM] run.away-AVR-PST.3[SG] no Petja[NOM] NEG.PST-PST.3SG.O.3SG.S
 kunda son'.
 catch PRON.3SG.GEN
 'Petja did not catch the third criminal that was also running away.'
- b. ^{OK}Pet'ε kunda-z'ə kolmæ-c'ə pr'istupn'ik-t' no son kεš-s'
 Petja[NOM] catch-PST.3SG.O.3SG.S three-ORD criminal-DEF.SG.GEN but PRON.3SG hide-PST.3[SG]
 saraj-sə.
 barn-IN
 'Peter also caught a third criminal, but he was hiding in a barn.'

- Relatives with ICA can be **restrictive** as well.

- (10) NOM ← GEN
 Koj kona pr'istupn'ik-n'ə-n' kona-t'n'ə-n' kunda-z'ən' Pet'ε
 INDEF which criminal-DEF.PL-GEN which-DEF.PL-GEN catch-PST.3PL.O.3SG.S Petja[NOM]
 vor'gəd'-kšn'ə-s'-t'.
 run.away-AVR-PST.3-PL
 'Some criminals that Petja caught were running away.'

- Under restrictive interpretation, example (10) denotes a non-empty intersection of a set of criminals arrested by Petja and a set of criminals that were running away. This enables the continuation in (11).

- (11) ^{OK}Kolmæ pr'istupn'ik-n'ə-n' Pet'ε iz'-əz'ən' kunda i kaft-t'n'ə
 three criminal-DEF.PL-GEN Petja[NOM] NEG.PST.3PL.O.3SG.S catch.CN and two-DEF.PL[NOM]
 maks'-s'-t' pr'ε sin'-c'.
 give-PST.3-PL head they-INT
 'Petja did not catch three criminals and two criminals surrendered themselves.'

- Relatives with ICA also show other properties typical for externally-headed relatives. As shown in (12), they allow for **stacking**.

- (12) NOM ← GEN
 Pεr'εkε-t' kona-n' pid'-əz'ə sas'ədə-z'ə kona-n' min'
 pie-DEF.SG.GEN which-GEN cook-PST.3SG.O.3SG.S neighbor-1SG.POSS.SG[NOM] which-GEN we[NOM]
 srazu seva-s'k ul'-s' kapsta-n'.
 immediately eat-PST.3.O.1PL.S be-PST.3[SG] cabbage-GEN
 'The pie that my neighbor cooked that we immediately ate was with cabbage.'

ICA patterns with externally-headed relatives.
--

- There is a number of other properties that were used as a diagnostic for the relative clause type in existing literature. These are **extraposition**, **extraction** out of the relative CP, and **obligatory left-peripheral position** of relatives with ICA.
- I will return to these properties later and show that they are fully compatible with current analysis and in fact shed no light on the position of the head inside or outside of the relative CP.

2.3 Structures for externally-headed relatives

- At least, two different structures were proposed for externally-headed relative clauses.
 - The head noun phrase may have a regular DP structure as in (13).
 - The NP may be in the specifier of an additional functional projection; see (14).

(13) Regular DP structure

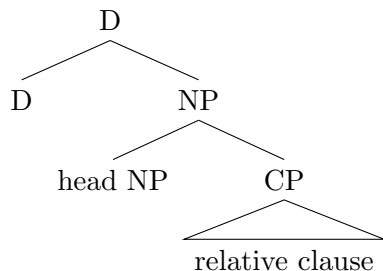

(14) NP in Spec,XP

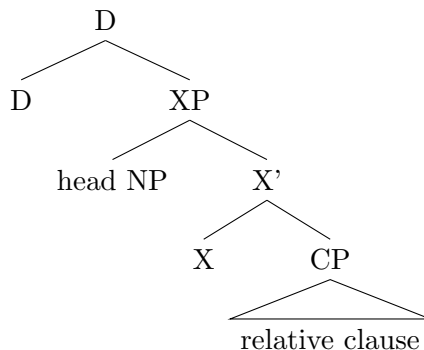

- The latter structure was proposed along with the raising derivation, according to which the head of the relative clause originates inside the relative CP and then moves out. Since movement targets specifiers, the head noun must be also in Spec.
- Analyses differ with respect to the identity of the X head: It can be one of the extended CP projections (see Bianchi (1999, 2000)) or some nominal head (see Bhatt (2002), Deal (2016)).
- I will show that independently what the X head is, structures in (14) cannot be correct.

Against NP in Spec,XP: Nominal inflection

- In (15), XP breaks down the spine of nominal projections, so that the noun is not D's complement, but appears in the specifier of D's complement. This makes wrong predictions for nominal inflection.
- Nouns in Moksha are morphologically marked for definiteness feature.

(15) kodamə bd'ə pin'ə-n'd'i (16) t'ε pin'ə-t'i
 how INDEF dog-DAT this dog-DEF.SG.DAT
 'to some dog' 'to this dog'

(17) *Lowering into Spec

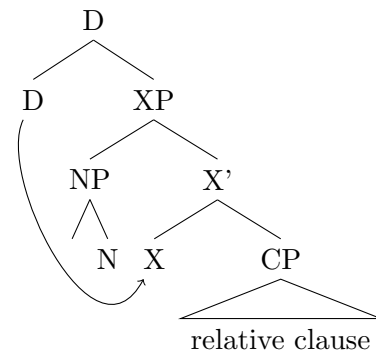

- Definiteness is often associated with the D head and can appear on the noun via Lowering (see Embick & Noyer (2001)) or head movement. Nouns in Moksha seem to remain low, which excludes head movement.
- Under the structure involving XP, definiteness is predicted to lower onto the X head instead of the noun (see (17)).
- The data in Moksha show that a noun in the head of the relative clause bears a regular definiteness inflection.

(18) a. NOM ← DAT
 T'ε pin'ə-t'i kona-n'd'i maks-in'ə jaṛca-ma-t' ašč-i dvor-sə.
 this dog-DEF.SG.DAT which-DAT give-PST.3.O.1SG.S eat-NZR-DEF.SG.GEN be-NPST.3[SG] yard-IN
 'This dog that I gave food is in the yard.'

b. NOM ← DAT
 Kodamə bd'ə pin'ə-n'd'i kona-n'd'i maks-in'ə jaṛca-ma-t' ašč-i ul'ic'a-sə.
 how INDEF dog-DAT which-DAT give-PST.3.O.1SG.S eat-NZR-DEF.SG.GEN be-NPST.3[SG] street-IN
 'Some dog that I gave food is on the street.'

- The argument can be generalized to be independent of Lowering: Data below show definiteness inflection in Moksha is not realized in the structural position occupied by the noun in (17); that is, inflection is not realized on specifiers (or other modifiers) of the main projection line.

(19) [Mosku-stə] poʒəzt-t'
 Moscow-EL train-DEF.SG.GEN
 ‘(see) the train from Moscow’

(20) Son n'ej-əz'ə [s'en'əm sel'mə] s't'ər'-n'ε-t'.
 she see-PST.3SG.O.3SG.S blue eye girl-DIM-DEF.SG.GEN

a. * [t'ε s'en'əm sel'mə] s't'ər'-n'ε-t'
 this blue eye girl-DIM-DEF.SG.GEN

b. [s'en'əm sel'mə-(*s'/*t'n'ə)] s't'ər'-n'ε-t'
 blue eye-DEF.SG[NOM]/DEF.PL[NOM] girl-DIM-DEF.SG.GEN
 ‘She saw the girl with these blue eyes.’

(21) NP modifier

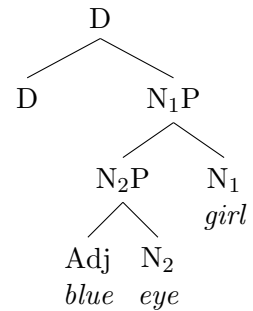

- The position of the head in Spec,XP is also problematic for other languages (cf. Heck (2005), Pankau (2018)).

Relatives with ICA have the following structure: [DP D [NP NP [CP_{rel} ...]]]

3 Connectivity effects

3.1 Background

- There are three major generation types proposed for externally-headed relative clauses.
1. **Raising**; see Schachter (1973), Vergnaud (1974), Kayne (1994), Sauerland (1998, 2003), Bianchi (1999), Bhatt (2002), De Vries (2002), Henderson (2007), Donati & Cecchetto (2011), Sportiche (2017).

(22) [DP head [CP __head C_{rel} ... __head]]

2. **Matching**; see Lees (1960, 1961), Chomsky (1965), Munn (1994), Sauerland (1998, 2003), Cresti (2000), Citko (2001), Salzmann (2006, 2017, 2018), Cinque (2015, 2020).

(23) [DP head [CP ~~head~~ C_{rel} ... __head]]

3. **External head**; see Partee (1975), Chomsky (1977), Jackendoff (1977), Platzack (2000), Boef (2012) as well as the handbooks by Haegeman (1994) and Heim & Kratzer (1998).

(24) [DP head [CP ... C_{rel} ...]]

- **Inverse case attraction** was initially taken to be one of the arguments for the raising analysis (see Bianchi (1999, 2000), Deal (2016)) but then re-analyzed.

- Relative clause internal origin of the head noun straightforwardly predicts the head can get its case assigned inside the relative clause.

(25) [DP head-DAT [CP __head_{DAT} C_{rel} ... predicate_[dat] __head-DAT] predicate_[nom]]

- However, it was later shown that matching and external head analyses can also capture the data.
- In matching derivation, it can be the internal head that is overt instead of the external one (see Cinque (2015, 2020), Wood et al. (2017), and to some extent Abramovitz (2021))

(26) [[DP ~~head-NOM~~ [CP head-DAT relative.pronoun-DAT ... predicate_[dat] ...]] ... predicate_[nom]]

- External head can also just agree with the relative pronoun in case (see Harbert (1983), Gračanin-Yuksek (2013), and also Bader & Meng (1999), Bader & Bayer (2006), Czypionka et al. (2018)).

(27) [[DP head [CP relative.pronoun-DAT C_{rel} ... predicate_[dat] ...]] ... predicate_[nom]]

↑
case

- On the basis of connectivity effects and comparison to regular externally-headed relatives as in (28), I will argue that relative clauses with ICA must be indeed analyzed by raising.

(28) Mon kurək n'ej-sa jalga-z'ə-n' [kona-n'd'i t'aš-n'ə-n'].
I soon see-NPST.3SG.O.1SG.S friend-1SG.POSS.SG-GEN which-DAT write-FREQ-PST.1SG
'I will soon see my friend to whom I have been writing.'

3.2 Data

Idioms

- The first diagnostic is based on the assumption that parts of an idiom must be base generated as a constituent (see Bach (1974), Chomsky (1980, 149-153), and McCawley (1998, 57)).
- If so, the ability of the head noun to build an idiom with a material from the relative CP and/or with a material from the main clause must shed light on the derivational path of the head noun.
- I will use idiom *pan'žəms potmə*. Its direct translation is 'to open guts/insides' and idiomatic meaning is 'to open up / to tell everything'.
- Example (29) shows that the head noun can build an idiom with the relative clause internal material only if the head noun has an internal case.

(29) NOM ← GEN
Potmə-nc/*c [kona-n' Vas'ε **pan'ž-əz'ə** ava-ncti]
gut-3SG.POSS.SG.GEN/*3SG.POSS.SG which-GEN Vasja[NOM] open-PST.3SG.O.3SG.S wife-3SG.POSS.SG.DAT
kunarə af maks-i pokoj.
long.ago NEG give-PST.3[SG] rest
'Everything that Vasja told to his wife was worrying him for a long time.'

- Example (30) illustrates that the idiom in the main clause is grammatical only if the head noun shows case assigned in the main clause.

(30) **Potmə-nc/*c** [kona kunarə af maks-i pokoj] Vas'ε
gut-3SG.POSS.SG.GEN/*NOM which[NOM] long.ago neg give-PST.3[SG] rest Vasja
pan'ž'-əz'ə ava-ncti
open-PST.3SG.O.3SG.S wife-DEF.SG.DAT
'Vasja opened his wife the secret that was worrying him for a long time.'

Anaphor binding

- The second diagnostic is based on binding of anaphors which according to Condition A of the standard Binding Theory must be bound by a local c-commanding syntactic object (see Chomsky (1981, 1986)).
- One of the ways to express reflexivity in Moksha is by pronoun *es'* 'self' (see Toldova & Shalганova (2018) for a recent description).

(31) Van'ε_i es'_{i/*j} var'aga-nc mu-z'ə.
Vanja[NOM] self mitten-3SG.POSS.SG.GEN find-PST.3SG.O.SG.S
{Context: Petja lost his mitten.} 'Vanja_i found his_i mitten.' (Toldova & Shalганova, 2018, 654)

- Anaphor in the head noun can be bound inside the relative CP only if the head has internal case.

(32) NOM ← GEN
Es'_i kud-ənc [kona-n' **Vas'**_{ε_i} mi-z'ə _____] t'en'i ašč-i
 self house-3SG.POSS.SG.GEN which-GEN Vasja[NOM] sell-PST.3SG.O.3SG.S now be-PST.3[SG]
 savə
 empty
 'His_i house that Vasja_i sold is now empty.'

(33) ***Es'**_i kud-əc [kona-n' **Vas'**_{ε_i} mi-z'ə _____] t'en'i ašč-i
 self house-3SG.POSS.SG[NOM] which-GEN Vasja[NOM] sell-PST.3SG.O.3SG.S now be-PST.3[SG]
 savə.
 empty
 Intended: 'His house that Vasja sold is now empty.'

- This dependency seems to be sufficient to diagnose the base position of the head noun, but I would like to strengthen the argument by excluding the possibility of binding by a logophoric center.
- Following Charnavel & Sportiche (2016), Charnavel (2019), and Charnavel & Bryant (2022), logophoric binding is excluded if a reflexive refers to an inanimate object, because inanimate objects cannot constitute a perspectival center; cf. (34).

(34) ***Es'** luv-ij-ənzə kelk-saz' t'ε **kn'iga-t'**.
 self read-PTCP.ACT-3SG.POSS.PL[NOM] love-NPST.3.O.3PL.S this book-DEF.SG.GEN
 Intended: 'Its_i readers love this book_i.'

- Applied to relative clauses, reflexives with an inanimate antecedent show the same dependency from the case marking on the head noun.

(35) NOM ← DAT
Es'_i luv-ij-ənzə-n'd'i [kona-t'n'ə-n'd'i t'ε **kn'iga-s'**_i maks-i _____
 self read-PTCP.ACT-3SG.POSS.PL-DAT which-DEF.PL-DAT this book-DEF.SG[NOM] give-NPST.3[SG]
 nad'əja-ma] uč-ij-t' pe.
 hope-NZR wait-NPST.3-PL end
 'Its_i readers whom this book_i gave hope are waiting for the continuation.'

(36) ***Es'** luv-ij-ənzə [kona-t'n'ə-n'd'i t'ε **kn'iga-s'** maks-i _____
 self read-PTCP.ACT-3SG.POSS.PL[NOM] which-DEF.PL-DAT this book-DEF.SG[NOM] give-NPST.3[SG]
 nad'əja-ma] uč-ij-t' pe.
 hope-NZR wait-NPST.3-PL end
 Intended: 'Its_i readers whom this book_i gave hope are waiting for the continuation.'

- Unlike the data on idioms in the last section, anaphor binding does not show a further dependency between case and binding in the main clause.

(37) GEN ← DAT
Es'_i mašina-**ncti**^{OK}**nc** [kona-n'd'i put-f lama jarmak] **Vas'**_{ε_i} dagə
 self car-3SG.POSS.SG.DAT/^{OK}GEN which-DAT put-PTCP.RES many money[NOM] Vasja[NOM] again
 pet'-əz'ə.
 repair-PST.3SG.O.3SG.S
 'Vasja_i again repaired his_i car that a lot of money was invested into.'

- Given that anaphor binding can apply at any stage of the derivation (cf. Barss (1986, 2001)), this result is expected.

Condition C

- The final diagnostic comes from Condition C, a requirement for R-expressions to be free throughout the derivation (see Chomsky (1981)).
- Relatives with the external case show no connectivity with respect to Condition C.

(38) **Puškin-ən'**_j kn'iga-**c** [kona-n' **son**_{i/j} t'εšt'-əz'ə _____
 Pushkin-GEN book-3SG.POSS.SG[NOM] which-GEN PRON.3SG[NOM] write-PST.3SG.O.3SG.S
 Pavləfskεj dača-sə] ašč-i bibl'iat'eka-sə-nək.
 pavlosk's country.house-IN be-NPST.3[SG] library-IN-1PL.POSS
 'Pushkin's book that he wrote in Pavlovsk's country house is in our library.'

- Coreference between the proper name in the head and the pronoun in the relative CP is not allowed with ICA.

(39) NOM ← GEN
Puškin-ən'_j kn'iga-**nc** [kona-n' **son**_{i/*j} t'εšt'-əz'ə _____ Pavləfskεj
 Pushkin-GEN book-3SG.POSS.SG.GEN which-GEN PRON.3SG[NOM] write-PST.3SG.O.3SG.S pavlosk's
 dača-sə] ašč-i bibl'iat'eka-sə-nək.
 country.house-IN be-NPST.3[SG] library-IN-1PL.POSS
 'Pushkin's book that he wrote in Pavlovsk's country house is in our library.'

Summary

(40) Connectivity in Moksha relative clauses

Diagnostics	RC with ICA	RC with external case
1. Idioms in the relative clause	OK	*
2. Idioms in the main clause	*	OK
3. Anaphor binding in the relative clause	OK	*
4. Anaphor binding in the main clause	OK	OK
5. Condition C in the relative clause	*	OK

3.3 Analysis

- I suggest that **relative clauses with ICA are derived by raising** as schematized in (41):
 - The head noun is base generated in the argument position in the relative CP. It obligatorily gets its case there and moves to the main clause after.

(41) Raising derivation for relatives with internal case

[DP head-INT.CASE [CP rel.pron C_{rel} ... __head-INT.CASE ...]]

- The derivational path of the head noun accounts for the connectivity profile.
 1. The base position of the head noun phrase inside the relative CP allows the head noun to participate in idioms inside the relative clause.
 2. The position of the head noun in the main clause is a derived one, so the requirement for parts of an idiom to be base generated together is not met.
 3. The presence of the head noun in the relativized position allows it to be locally c-commanded and thus bound by higher noun phrases inside the relative CP.
 4. After movement, the head noun occupies the position in the main clause and can therefore be bound there as well.

5. I assume that condition C applies in syntax and cases where some parts of a moved syntactic object can obviate it are derived by late merge (cf. Takahashi & Hulsey (2009)). Since heads with internal case must be in the relative CP to get their case, the analysis also correctly predicts that they are evaluated for condition C inside relative CPs.

• **Relatives with external case are derived by the head-external generation:**

(42) Head-external derivation for relatives with external case

[DP head-EXT.CASE [CP rel.pron C_{rel} ...]]

- Since the head noun is first merged in the main clause, it does not get the case marking inside the relative CP. It also cannot form an idiom with a relative CP internal material, be bound there, or evaluated with respect to condition C.
- Idiomatic interpretation in the main clause, on the other hand, is possible, because the the head is base generated there.

- This analysis supports the co-existence of two structures for relative clauses in one language (Sauerland 1998; Bhatt 2002; Harris 2008) and provides yet another case where superficially similar phenomena have distinct analyses.

Alternatives: Other derivations alone or in combinations fail to derive the data.

- **The head-external only approach** could in principle capture ICA as in (43), but not the correspondence between connectivity and case.

(43) ICA by agreement

[DP head-INT.CASE [CP rel.pron-INT.CASE C_{rel} ... __rel.pron ...]]



- For **raising only approach** to derive this correlation, it needs to be somehow ensured that nouns are interpreted in their case positions.

(44) Raising only

a. [DP __ [CP rel.pron C_{rel} ... head-INT.CASE ...]]



b. [DP head-EXT.CASE [CP rel.pron C_{rel} ... __ ...]]



- This however would be at variance with the anaphor binding data showing that heads with internal case can be present in the main clause position for binding.
- For **matching** to derive ICA, the internal head must move to the main clause across the relative pronoun, thereby forcing matching derivation to include raising as its proper subpart.

(45) [head [head [CP [DP_{rel} rel.pron- α __head] C_{rel} ... __DP_{rel} ...]]]



- **The matching only view** further requires that the same head (internal or external) is deleted or interpreted at both PF and LF, contrary to known applications (see Salzmann (2018)) and the anaphor binding data.

Relatives with internal case are derived by raising.
 Relatives with external case follow from head-external generation.

4 The syntax of raising

- The data so far have shown that
 - The final structure of relative with ICA is in (46).

(46) [DP D [NP NP [CP_{rel} ...]]]

- The head moves from the CP-internal position:

(47) [DP head [CP —head C_{rel} ... —head]]

- Since movement typically proceeds to a specifier position (cf. (48)), providing an analysis that meets both empirical conclusions is surprisingly not trivial.

(48) Standard movement to the specifier

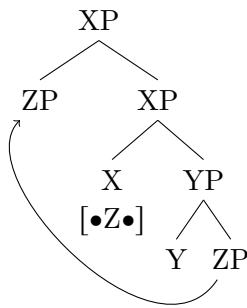

- What seems to be required instead is **projecting movement of the head**.
- One such approach was developed by Donati & Cecchetto (2011), Cecchetto & Donati (2016)).
 - This approach relies on one of the core ideas of Chomsky's recent labeling algorithm (see Chomsky (2013)) that heads always project.
 - In result, the projecting head must be syntactic terminals, contrary to the data.

(49) NOM ← DAT

Es_i luv-ij-ənzə-n'd'i [kona-t'n'ə-n'd'i t'ε kn'iga-s'_i maks-i
 self read-PTCP.ACT-3SG.POSS.PL-DAT which-DEF.PL-DAT this book-DEF.SG[NOM] give-NPST.3[SG]
 nad'əja-ma] uč-ij-t' pe.
 hope-NZR wait-NPST.3-PL end
 'Its_i readers whom this book_i gave hope are waiting for the continuation.'

- It is thus the phrase that must project in the landing site.

4.1 Projecting movement

- A possibility for a displaced syntactic object to project in its landing site arises under projection by selection model (see Chomsky (1995), Adger (2003) as well as Stabler (1997)) if movement is triggered by a feature on a displaced syntactic object.

(50) Projection by selection:

The item that selects is the item that projects.

(51) Merge

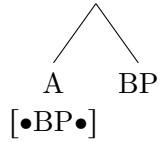

(52) Labeling

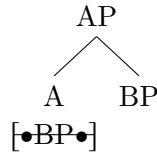

- If a merge feature can search upwards (cf. Baker (2008), Wurmbrand (2012), Zeijlstra (2012), Himmelreich (2017), and Bjorkman & Zeijlstra (2019), i.a.), projecting movement is predicted.

(53) Base position

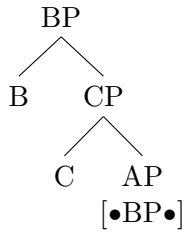

(54) Movement and projection

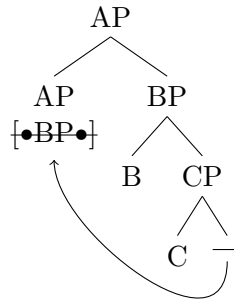

- Raising relative clauses have the following derivation.

(55) Numeration for raising relative clauses:

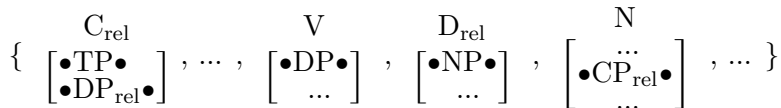

(57) Step 2: Relative CP

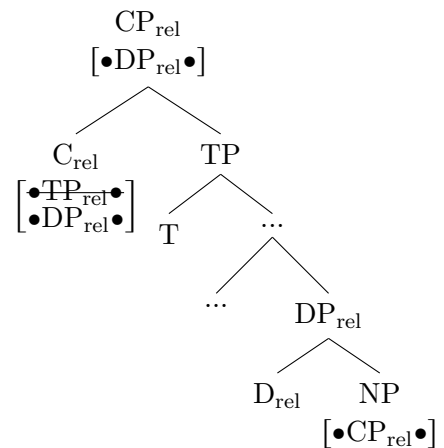

(56) Step 1: Relative DP

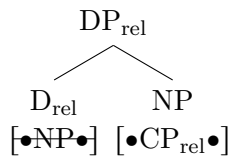

- After Merge of C_{rel} , there are two unordered active selection features that have both located their goals: $[•DP_{rel}•]$ and $[•CP_{rel}•]$.
- I suggest that copies of the two syntactic objects that are to be displaced are then subsequently created and merged to the workspace and organized there in a stack (see Heck (2016), Heck & Himmelreich (2017)), similarly to features on the heads.
- I further assume that the upward search is given precedence over the downward search (cf. Assmann et al. (2015) and Bjorkman & Zeijlstra (2019)), so that the head NP is copied first.

(58) Step 3: Search and copying

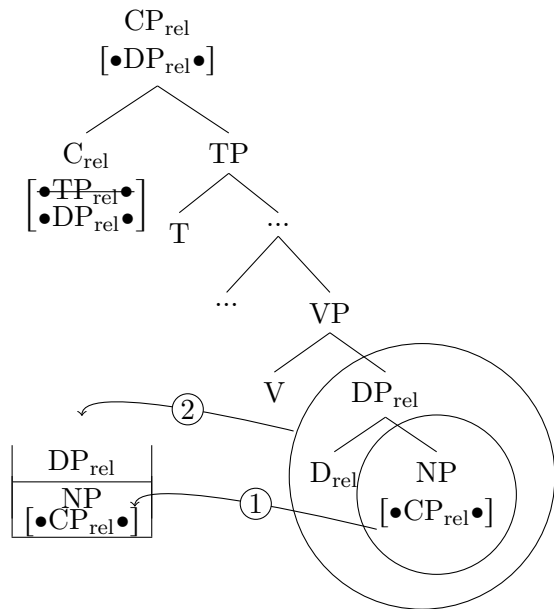
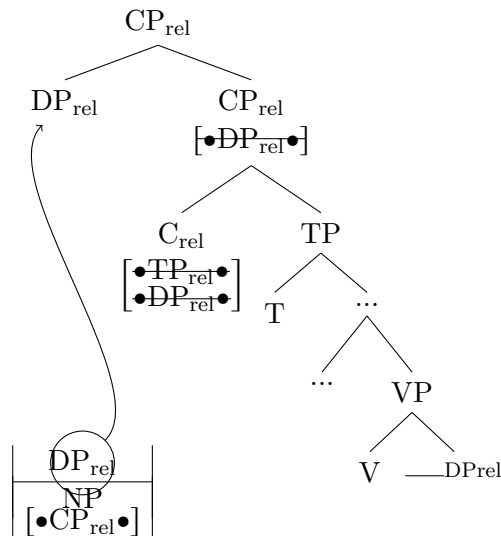
(59) Step 4: Merge of DP_{rel}

(60) Step 5: Merge of the head NP

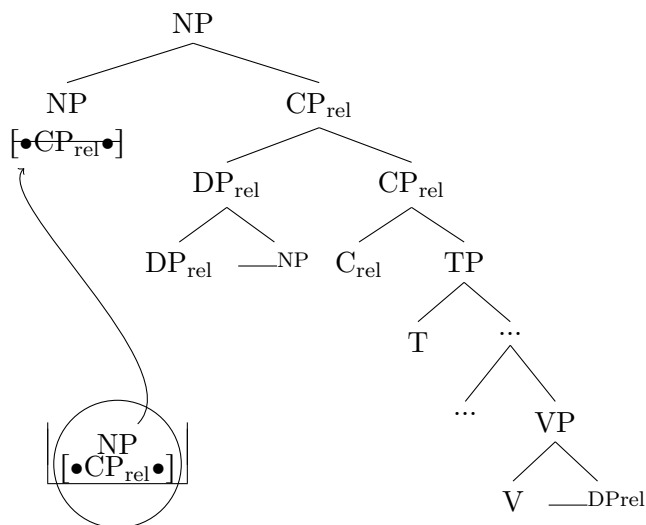

(61) Step 6: Merge of the external D head

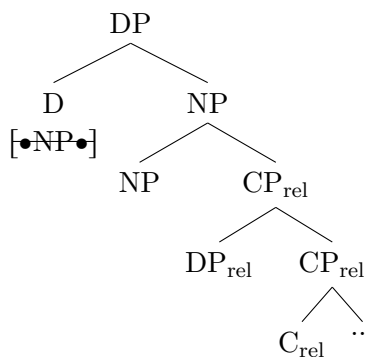

4.2 Internal vs. external case

- Raising derivation yield internal case on the head in Moksha. Besides Moksha, such internal case marking of the head is attested in a number of languages; see Ancient Greek (Grimm (2005, 78-92)), Latin (Touratier (1980, 147-211)), Vedic and Sanskrit (Gonda (1975, 195)), Middle High German (Pittner (1995)), non-standard Icelandic (Wood et al. (2017)), Besermyan Udmurt (Belyaev (2012), Kholodilova & Privizentseva (2015)), Ingrian Finnish (Kholodilova (2013)), Nez Perce (Deal (2016)), and Koryak (Abramovitz (2021)) among others.
- However, raising with external case is attested in other languages; see, for instance, example (62) from German showing anaphor binding into the head by relative CP internal material.

- (62) Der Wesenszug von **sich**_i, [den **Peter**_i noch nicht — kannte], störte
 the.NOM trait of self which.ACC Peter still not know.PST.3SG annoy.PST.3SG
 niemanden.
 no.one.ACC
 ‘No one was annoyed by the side of himself_i that Peter_i did not know yet.’

(Salzmann, 2006, 99)

- Different orderings of the [\bullet CP_{rel} \bullet] merge feature and a case probe on the head NP underlie the difference in case marking.

(63) Case marking on the head under raising

Pattern	Ordered features on the N head
1. Internal case (Languages with ICA) <i>Latin, Moksha, Nez Perce etc.</i>	[*case:___*] < [\bullet CP _{rel} \bullet]
2. External case <i>German, Russian, Italian etc.</i>	[\bullet CP _{rel} \bullet] < [*case:___*]

(64) Internal case: In the relative CP

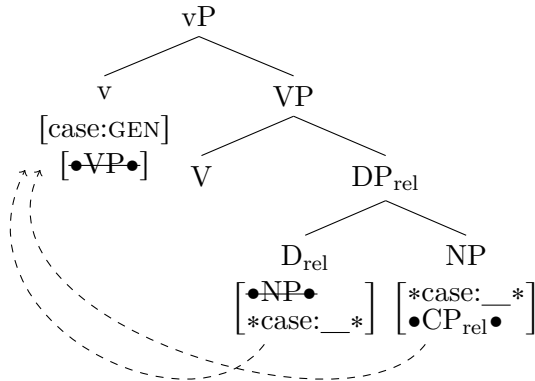

(65) Internal case: In the main clause

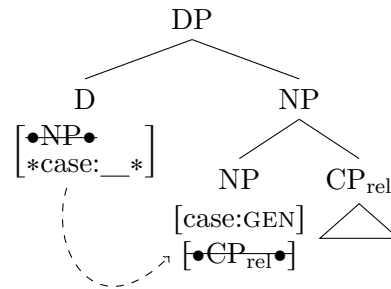

(66) External case: In the relative CP

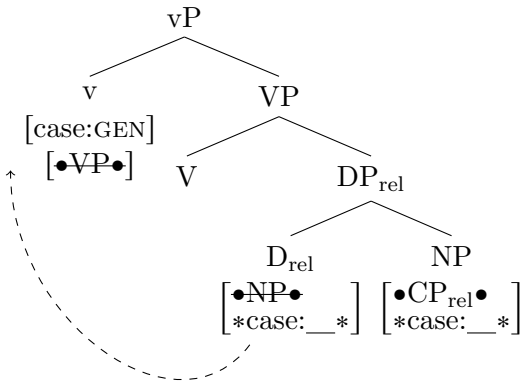

(67) External case: In the main clause

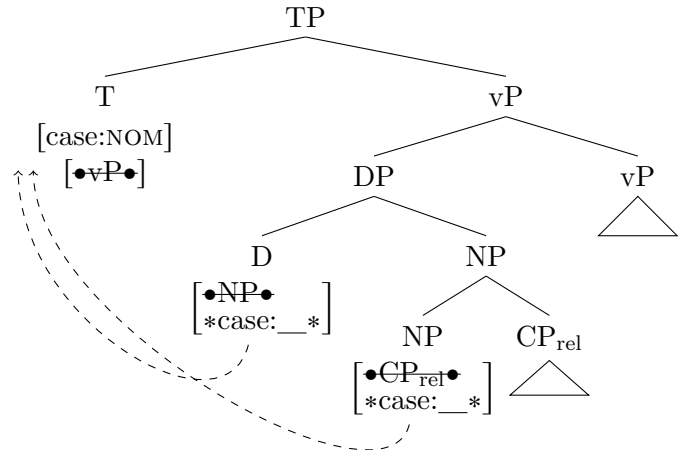

- This provides a novel perspective on one of the long-standing issues in the syntax of raising: Despite originating in a case position in the relative CP, the head shows a case assigned in the main clause in most languages (see Borsley (1997)).
- The current analysis allows to account for a delayed valuation of a case feature by ordering the feature lower in the feature stack and thus shielding it from the probing at earlier stages.
- This approach seems to be also applicable to other case overwriting phenomena (see Bejar & Massam (1999), Merchant (2006), Potsdam (2006), Boeckx et al. (2010), Fong (2019), i.a), but this remains subject to further research.

5 Conclusions

1. Raising derivation is part of natural language syntax. Raising derivation co-exists with the head-external structure.
2. Raising derivation involves projecting movement of the head noun that follows from projection by selection algorithm combined with the possibility of upward search.
3. Ordering of features allows to derive internal case on raising heads in Moksha and external case in other languages.
4. An approach to syntax, where Merge is feature-driven and labeling is derived via projection by selection algorithm allows to account for non-trivial empirical phenomena.

6 Further properties

6.1 Extraposition

- Extraposition of the relative CP is ungrammatical if the head is marked for the internal case.

(68) NOM ← DAT
 *S't'ər'-n'ε-t'i tu-s' kaftə n'ed'el'a-t [kona-n'd'i maks-in'ə kel'gəma
 girl-DEF.SG.DAT go-PST.3[SG] two week-PL which-DAT give-PST.3.O.1SG.S favorite
 kn'iga-z'ə-n'].
 book-1SG.POSS.SG-GEN
 ‘The girl left for two weeks, whom I gave my favorite book.’

- Abramovitz (2021) takes analogous data in Koryak as an indication that relative clauses with ICA are internally-headed.
- In fact, ban on extraction is typical for raising relatives (see Hulsey & Sauerland (2006), Takahashi & Hulsey (2009)) and follows from the analysis of extraposition by Fox & Nissenbaum (1999):
 - Having final landing site outside of the relative CP, the head that originates in the relative CP still cannot be merged with the main clause first.

(69) a. Movement of the head NP

[_{MC} [... DP ...] DP]

b. Late adjunction of the relative CP and realization of the lower copy

[_{MC} [... DP ...] [_{DP} [_{CP} rel.pron ...]]]

6.2 Extraction out of the relative clause

- Relatives with internal case allow extraction out of the relative CP, but this is ungrammatical for relatives with external case.

(70) NOM ← DAT
Bibl'iat'eka-stə [jalga-z'ə-n'd'i/*∅ [kona-n'd'i mon sɛv-in'ə kn'iga-t'
 library-EL friend-1SG.POSS.SG-DAT/*NOM which-DAT I[NOM] take-PST.3.O.1SG.S book-DEF.SG.GEN
 ___]] kelk-si luv-əm-s.
 love-NPST.3SG.O.3SG.S read-INF-ILL
 ‘My friend for whom I took the book from the library loves to read.’

- For Koryak, Abramovitz (2021) assumes that adjuncts are inside the relative CP, in one of the split-CP projections. The data then strongly argue that relatives with ICA are internally-headed.
- Data in (71) show that displaced phrase can be interleaved with the main clause material and is thus outside of the relative CP.

(71) NOM ← GEN
 Bibl'iat'eka-stə mon ar's'-an [čtə [kn'iga-t' kona-n' sɛv-əz'ə
 library-EL I[NOM] think-NPST.3[SG] that book-DEF.SG.GEN which-GEN take-PST.3SG.O.3SG.S
 Kat'ε] ašč-i stol-sə].
 Katja be-NPST.3[SG] table-IN
 'I think that the book that Katja took from the library is on the table.'

- While relative clauses are a textbook example of island structures (see Ross (1967)), there are numerous examples in the literature showing that extraction out of a relative clause is possible under certain conditions; see Erteschik-Shir (1973), McCawley (1981), Engdahl (1997), Cinque (2010), Kush et al. (2013), Sichel (2018), Vincent (2021).
- Most recently, investigating extraction out of relative clauses in Hebrew, Sichel (2018) suggested that extraction is enabled by the raising derivation.
- I would like to suggest that extraction out the relative clause in Moksha is related to the raising derivation, to the internal case marking on the head in particular.
- I assume that
 - CPs as well as DPs (see Svenonius (2004), Matushansky (2004), Bošković (2014)) are phases and syntactic objects must move to their edge to escape.
 - In Moksha edge features that allow syntactic objects to move to the DP edge are ordered after the case probe, so that movement to the DP edge is possible only after the DP got its case.
- As heads of relative clauses with ICA have case from inside the relative clause, their edge features are readily available when the DP is first build.

(72) External D gets case

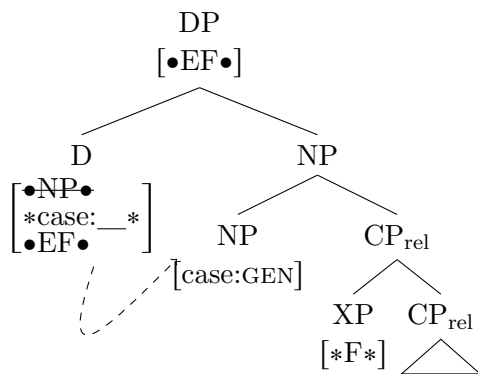

(73) Movement to DP edge

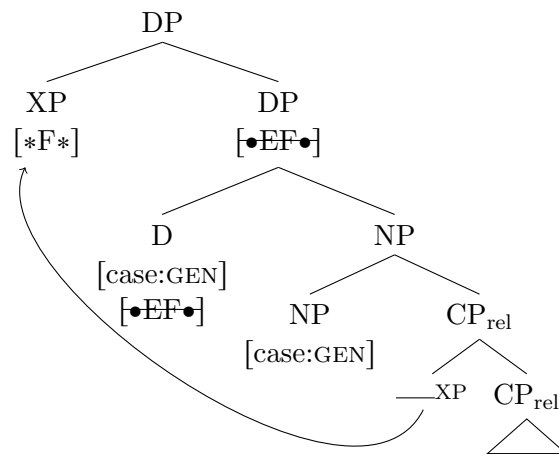

- Heads of regular externally-headed relative clauses, on the contrary, receive case from higher projections in the main clause, when the material in the complement is already rendered inaccessible for movement.

(74) *Extraction

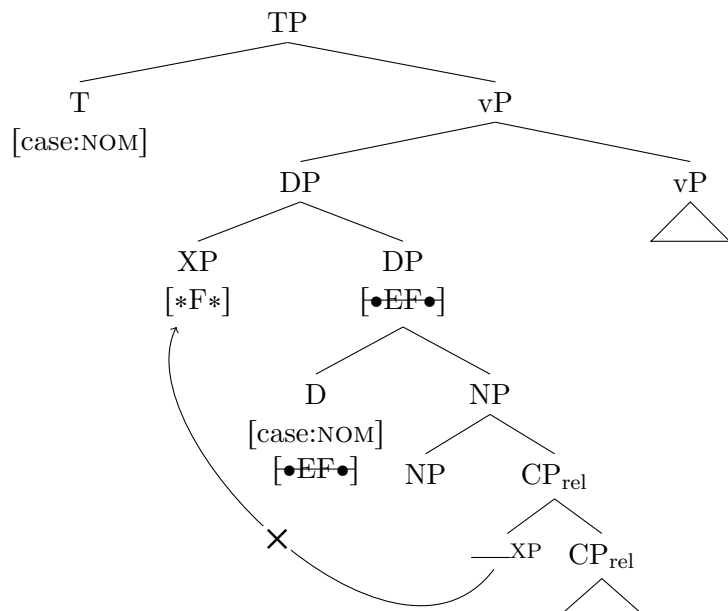

6.3 Left periphery restriction

6.3.1 Basics

- Relative clauses with case attraction must be on the left periphery as in (75).

(75) GEN ← DAT
Škaf-t'i, **kona-n'd'i** mon put-in'ə fətəgrafijə-t'n'ə-n', min'
 closet-DEF.SG.DAT which-DAT I[NOM] put-PST.3.O.1SG.S photo-DEF.PL-GEN we[NOM]
 jorda-s'k.
 throw.away-PST.3.O.1PL.S
 'We threw away the closet in which I put the photos.'

- They cannot be embedded in the main clause; see (76).

(76) GEN ← DAT
 *Min' jorda-s'k **škaf-t'i,** **kona-n'd'i** mon put-in'ə
 we[NOM] throw.away-PST.3.O.1PL.S closet-DEF.SG.DAT which-DAT I[NOM] put-PST.3.O.1SG.S
 fətəgrafijə-t'n'ə-n'.
 photo-DEF.PL-GEN
 'We threw away the closet in which I put the photos.'

- Relative clauses with case attraction cannot follow just an argument from the main clause; see (77).

(77) GEN ← DAT
 *Min', **škaf-t'i,** **kona-n'd'i** mon put-in'ə fətəgrafijə-t'n'ə-n',
 we[NOM] closet-DEF.SG.DAT which-DAT I[NOM] put-PST.3.O.1SG.S photo-DEF.PL-GEN
 jorda-s'k.
 throw.away-PST.3.O.1PL.S
 'We threw away the closet in which I put the photos.'

- This restriction is attested for relative clauses with inverse case attraction in virtually all languages where the phenomenon is present (see Bianchi (1999), Kholodilova (2013), Kholodilova & Privizentseva (2015), Deal (2016), Abramovitz (2021)).

- It groups relatives with ICA and correlatives that are typically located on the left periphery (see Srivastav (1991), Dayal (1996), Lipták (2009), Lin (2020)).

(78) **Kona škaf-t'i** mon put-in'ə fətəgrafijə-t'n'ə-n', min'
 which closet-DEF.SG.DAT I[NOM] put-PST.3.O.1SG.S photo-DEF.PL-GEN we[NOM]
 jorda-s'k (s'ɛ-n').
 throw.away-PST.3.O.1PL.S that-GEN
 'We threw away the closet in which I put the photos.'

- Unlike correlatives (in Moksha), relatives with ICA are not base generated, but moved to the left (*pace* Deal (2016) on Nez Perce).
- First, they cannot refer to a position inside an island.

(79) NOM ← GEN
 ***Katə-t'**, **kona-n'** t'ejə-n kəz'-əz', mon ul'-an kən'er'd'-f,
 cat-DEF.SG.GEN which-GEN PRON.DAT-1SG.POSS gift-PST.3.O.3PL.S I[NOM] be-NPST.1SG happy-PTCP.RES
 kədə ___ karma-j kunc'-əmə šejəṛ'-t'.
 if ___ become-NPST.3[SG] catch-FREQ.INF mouse-PL
 'I will be happy if the cat that they gifted to me starts catching mice.'

- Second, a variable inside the relative clause with ICA can be bound by a quantified noun phrase in the main clause.

(80) GEN ← DAT
Pin'ə-t'i, kona-n'd'i son_i maks-əz'ə jaṛcambəl'-t', ɛr'
 dog-DEF.SG.DAT which-DAT PRON.3SG[NOM] give-PST.3SG.O.3SG.S food-DEF.SG.GEN every
s'ora-n'ɛ-s'i mɛl'aft-əz'ə.
 boy-DIM-DEF.SG[NOM] remember-PST.3SG.O.3SG.S
 'Every boy_i remembered the dog that he_i gave food.'

- Third, relatives with ICA can be coordinated with a noun phrase that shows case assigned in the main clause.

(81) GEN ← DAT
 Ečkə **katə-t'** i osal **pin'ə-t'i**, kona-n'd'i ton maks-at jaṛca-ma, mon
 thick cat-DEF.SG.GEN and skinny dog-DEF.SG.DAT which-DAT you give-NPST.2SG eat-NZR I
 soda-sajn'ə.
 know-NPST.3PL.O.1SG.S
 'I know the skinny dog that you give food and the fat cat.'

- Fourth, anaphors in heads of relatives with ICA can be bound in the main clause.

(82) GEN ← DAT
 [**Es'**_i mašina-**ncti** kona-n'd'i put-f lama jarmak] **Vas'ɛ**_i dagə
 self car-3SG.POSS.SG.DAT which-DAT put-PTCP.RES many money[NOM] Vasja[NOM] again
 pet'-əz'ə.
 repair-PST.3SG.O.3SG.S
 'Vasja_i again repaired his_i car that a lot of money was invested into.'

- Relative clauses with inverse case attraction have a derivation illustrated in (83a-b).

(83) Relative clauses with inverse case attraction
 a. [MC ... predicate ... [head [CP ...]] ...]
 b. [[head [CP ...]] [MC ... predicate ... ___ ...]

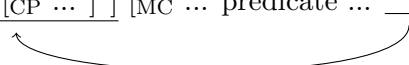

6.3.2 Analysis

- This is an instance of **forced ex-situ effect**: Two syntactic objects can form a constituent at some stage of the derivation but not in the resulting structure.

- (84) a. Intermediate: [X Y] – OK
 b. Final: Y [X ___] – OK
 c. Final: [X Y] – *

- This type of data were accounted for by Chomsky’s recent labeling algorithm (see Chomsky (2013, 2015) and Ott (2012, 2015)), but as I will show here can be also derived under projection by selection approach to labeling.
- I assume that merge features select not only for a category, but also for unchecked agreement or merge features.

- (85) Regular merge feature: $\begin{array}{c} Y \\ [\bullet x \bullet] \end{array}$

- (86) Secondary selection features: $\begin{array}{c} Y \\ [\bullet x_{[*F*]} \bullet] \end{array}$

- (87) Selection and projection:

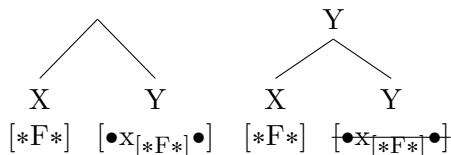

- Relatives with ICA are peculiar in that the head moves to a case position in the main clause after it has already been assigned case in the relative clause.
- Movement of a case marked noun to yet another case position seems to be rare cross-linguistically and I would like to suggest that this restriction arises, because verbal heads in fact select for nouns with an unchecked case feature; see (88).
- The requirement is loosened in Moksha as well as with in other languages with ICA, so that the nature of the unchecked agreement feature is underspecified as in (89).

- (88) No ICA: $\begin{array}{c} V \\ [\bullet D_{[*case*]} \bullet] \end{array}$

- (89) With ICA: $\begin{array}{c} V \\ [\bullet D_{[*F*]} \bullet] \end{array}$

- As heads of relatives with ICA receive the case inside the relative clause, the DP must bear yet another active probe to satisfy the selection requirement.
- I suggest that that it forces the presence of an \bar{A} -related probe that inevitably leads to movement of the whole DP to the left.
 - A-movements such as passivization or subject movement to Spec,TP are cross-linguistically related to case that is already valued on relatives with ICA.
 - I also suggest that the same holds for local clause-internal scrambling: It is driven by optional EPP features (or $[\bullet DP \bullet]$ in the current notation) on clausal heads, but do not require active features on DPs themselves (cf. Miyagawa (2001), Bailyn (2004)).

(90) External D

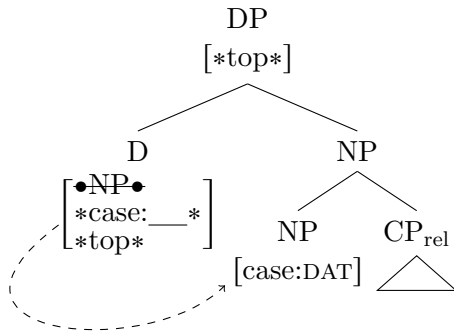

(91) Selection in the main clause

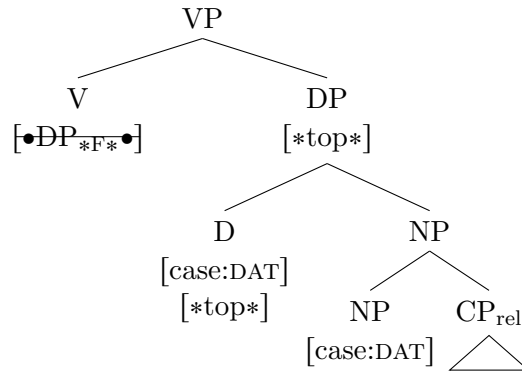

- Due to its active topic probe, the DP agrees with the C head and is then attracted to its specifier (see (92)).

(92) Movement to the left

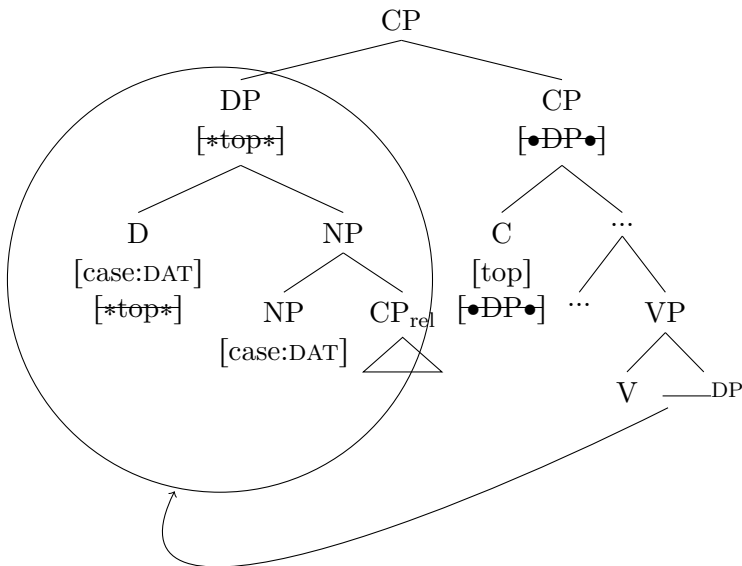

- Notably, if a DP that contains the relative clause with ICA does not have an active probe, it cannot be selected by a head in the main clause and the derivation crashes; see (93).

(93) *Relatives with ICA: No additional probe

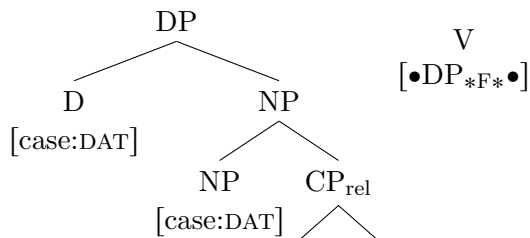

References

- Abramovitz, R. 2021. Deconstructing Inverse Case Attraction. Ms., Massachusetts Institute of Technology.
 Adger, D. 2003. *Core Syntax: A Minimalist Approach*. Oxford: Oxford University Press.

- Assmann, A., D. Georgi, F. Heck, G. Müller & P. Weisser. 2015. Ergatives move too early: On an instance of opacity in syntax. *Syntax* 18:343–387.
- Bach, E. 1974. *Syntactic Theory*. New York: Holt, Rinehart, and Winston.
- Bader, M. & J. Bayer. 2006. *Case and linking in language comprehension evidence from German*. Dordrecht: Springer.
- Bader, M. & M. Meng. 1999. Case Attraction Phenomena in German. Ms., University of Jena.
- Bailyn, J. F. 2004. Generalized inversion. *Natural Language & Linguistic Theory* 9.
- Baker, M. 2008. *The Syntax of Agreement and Concord*. New York: Cambridge University Press.
- Barss, A. 1986. Chains and anaphoric dependence. Doctoral thesis, Massachusetts Institute of Technology, Cambridge, MA.
- Barss, A. 2001. Syntactic reconstruction effects. In *The Handbook of Contemporary Syntactic Theory*, eds. M. Baltin & C. Collins, chapter 21, 670–696. John Wiley & Sons, Ltd.
- Bejar, S. & D. Massam. 1999. Multiple case checking. *Syntax* 2:65–79.
- Belyaev, O. I. 2012. Korreljativnaja konstrukcija i odnositel'nye predloženiya s vnutrennej veršinoj v besermjanskom dialekte udmurtskogo jazyka. In *Finno-ugorskie jazyki: Fragmenty grammatičeskogo opisanija*, ed. A. I. Kuzniciva, 647–679. Moskva: Jazyki slavjanskoj kul'tury.
- Bhatt, R. 2002. The Raising Analysis of Relative Clauses: Evidence from Adjectival Modification. *Natural Language Semantics* 10:43–90.
- Bhatt, R. 2005. Three Theories of Relative Clauses. Handout for the class “The Syntax and Semantics of Nominal Modification” at LOT Summer School 2005, Universiteit Leiden.
- Bianchi, V. 1999. *Consequences of Antisymmetry. Headed Relative Clauses*, volume 46 of *Studies in generative grammar*. Berlin: Mouton de Gruyter.
- Bianchi, V. 2000. Some Issues in the Syntax of Relative Determiners. In *The syntax of relative clauses*, volume 32 of *Linguistik aktuell / Linguistics today*, eds. A. Alexiadou, P. Law, A. Meinunger & C. Wilder, 53–83. Amsterdam, Philadelphia: John Benjamins.
- Bjorkman, B. M. & H. Zeijlstra. 2019. Checking Up on (ϕ -)Agree. *Linguistic Inquiry* 50:527–569.
- Boeckx, C., N. Hornstein & J. Nunes. 2010. Icelandic control really is A-movement: Reply to Bobaljik and Landau. *Linguistic Inquiry* 41.
- Boef, E. 2012. Doubling in relative clauses: Aspects of morphosyntactic microvariation in Dutch. Doctoral thesis, Universiteit Utrecht.
- Borsley, R. D. 1997. Relative clauses and the theory of phrase structure. *Linguistic Inquiry* 28:629–647.
- Bošković, Ž. 2014. Now I’m a Phase, Now I’m Not a Phase: On the Variability of Phases with Extraction and Ellipsis. *Linguistic Inquiry* 45:27–89.
- Brasoveanu, A. 2012. Correlatives. *Language and Linguistics Compass* 6:1–20.
- Cecchetto, C. & C. Donati. 2016. *(Re)labeling*. Cambridge, MA: MIT Press.
- Charnavel, I. 2019. *Locality and logophoricity: A theory of exempt anaphora*. Oxford: Oxford University Press.
- Charnavel, I. & S. Bryant. 2022. Disentangling locality, logophoricity and subjecthood in english picture noun anaphora. Ms., Université de Genève and Harvard University. To appear in NLLT.
- Charnavel, I. & D. Sportiche. 2016. Anaphor binding: What French inanimate anaphors show. *Linguistic Inquiry* 47:35–87.
- Chomsky, N. 1965. *Aspects of the Theory of Syntax*. Cambridge, MA: MIT Press.
- Chomsky, N. 1977. On Wh-Movement. In *Formal Syntax*, eds. P. Culicover, T. Wasow & A. Akmajian, 71–132. New York: Academic Press.
- Chomsky, N. 1980. *Rules and Representations*. Columbia classics in philosophy, New York: Columbia University Press.
- Chomsky, N. 1981. *Lectures on Government and Binding*. Dordrecht: Foris.
- Chomsky, N. 1986. *Knowledge of Language*. Dordrecht: Foris.
- Chomsky, N. 1995. *The Minimalist Program*. Cambridge: MIT Press.
- Chomsky, N. 2013. Problems of projection. *Lingua* 130:33–49.
- Chomsky, N. 2015. Problems of projection: Extensions. In *Structures, strategies, and beyond: Studies in honour of Adriana Belletti*, eds. E. Domenico, C. Hamann & S. Matteini, 3–16. Amsterdam: John Benjamins.
- Cinque, G. 2010. On a selective ‘violation’ of the Complex NP Constraint. In *Structure preserved: Studies in syntax for Jan Koster*, eds. C. J.-W. Zwart & M. de Vries, 81–90. Amsterdam: John Benjamins.
- Cinque, G. 2015. Three phenomena discriminating between “raising” and “matching” relative clauses. *Semantics-Syntax Interface* 2:1–27.
- Cinque, G. 2020. *The Syntax of Relative Clauses: A Unified Analysis*. Cambridge Studies in Linguistics, Cambridge: Cambridge University Press.
- Citko, B. 2001. Deletion under Identity in Relative Clauses. *North East Linguistics Society* 31:131–145.
- Cresti, D. 2000. Ellipsis and Reconstruction in Relative Clauses. *North East Linguistics Society* 30:153–163.
- Czypionka, A., L. Dörre & J. Bayer. 2018. Inverse Case attraction: experimental evidence for a syntactically guided process. *The Journal of Comparative Germanic Linguistics* 21:135–188.
- Dayal, V. 1996. *Locality in wh-quantification*. Dordrecht: Kluwer.
- Deal, A. R. 2016. Cyclicity and Connectivity in Nez Perce Relative Clauses. *Linguistic Inquiry* 47:427–470.
- Donati, C. & C. Cecchetto. 2011. Relabeling Heads: A Unified Account for Relativization Structures. *Linguistic Inquiry*

- Embick, D. & R. Noyer. 2001. Movement Operations after Syntax. *Linguistic Inquiry* 32:555–595.
- Engdahl, E. 1997. Relative clause extractions in context. *Working Papers in Scandinavian Syntax* 51–79.
- Erteschik-Shir, N. 1973. On the nature of island constraints. Doctoral thesis, Massachusetts Institute of Technology, Cambridge, MA.
- Fong, S. 2019. Proper movement through Spec-CP: an argument from hyperraising in Mongolian. *Glossa: a journal of general linguistics* 4:30.
- Fox, D. & J. Nissenbaum. 1999. Extraposition and scope: A case for overt QR. In *Proceedings of the 18th West Coast Conference on Formal Linguistics (WCCFL18)*, eds. S. Bird, A. Carnie, J. D. Haugen & P. Norquest, 132–144. Somerville, MA: Cascadilla Press.
- Georgi, D. 2017. Patterns of movement reflexes as the result of the order of Merge and Agree. *Linguistic Inquiry* 48:585–626.
- Georgi, D. & M. Salzmann. 2017. The matching effect in resumption: a local analysis based on Case attraction and top-down derivation. *Natural Language & Linguistic Theory* 35:61–98.
- Gonda, J. 1975. *Selected Studies: Indo-European linguistics*. Leiden: Brill.
- Gračanin-Yukseš, M. 2013. The syntax of relative clauses in Croatian. *The Linguistic Review* 30:25–49.
- Grimm, S. M. 2005. Lattice of case and agentivity. Master’s thesis, Universiteit van Amsterdam, Amsterdam.
- Grosu, A. 2002. Strange relatives at the interface of two millennia. *GLOT International* 6:145–167.
- Grosu, A. 2012. Towards a more articulated typology of internally headed relative constructions: The semantics connection. *Language and Linguistics Compass* 6:447–476.
- Grosu, A. & F. Landman. 1998. Strange relatives of the third kind. *Natural Language Semantics* 6:125–170.
- Haegeman, L. 1994. *Introduction to Government and Binding Theory*, volume 1 of *Blackwell textbooks in Linguistics*. Oxford: Blackwell, 2 edition.
- Hanink, E. A. 2021. DP structure and internally headed relatives in Washo. *Natural Language & Linguistic Theory* 39:505–554.
- Harbert, W. 1983. A note on old english free relatives. *Linguistic Inquiry* 14:549–553.
- Harris, J. A. 2008. On the syntax and semantics of Heim’s ambiguity. In *Proceedings of the 27th West Coast Conference on Formal Linguistics*, eds. N. Abner & J. Bishop, 194–202. Somerville, MA: Cascadilla.
- Heck, F. 2005. Gegen Kopfanhebung in deutschen Relativsätzen. Talk presented at Tagung zur Generativen Grammatik des Südens (GGS), Universität Tübingen.
- Heck, F. 2016. Non-monotonic derivations. Habilitation, Universität Leipzig, Leipzig.
- Heck, F. & A. Himmelreich. 2017. Opaque intervention. *Linguistic Inquiry* 48:47–97.
- Heim, I. & A. Kratzer. 1998. *Semantics in Generative Grammar*, volume 13 of *Blackwell textbooks in Linguistics*. Oxford: Blackwell.
- Henderson, B. 2007. Matching and raising unified. *Lingua* 117:202–220.
- Himmelreich, A. 2017. Case matching effects in free relatives and parasitic gaps: A study on the properties of agree. Ph.D. thesis, Universität Leipzig.
- Hucklebridge, S. 2022. Implementing head-internal relativization in a bare noun language. Ms., University of Massachusetts at Amherst.
- Hulsey, S. & U. Sauerland. 2006. Sorting out relative clauses. *Natural Language Semantics* 14:111–137.
- Jackendoff, R. 1977. *X̄-Syntax: A Study of Phrase Structure*, volume 2 of *Linguistic Inquiry Monographs*. Cambridge, MA: MIT Press.
- Kayne, R. S. 1994. *The Antisymmetry of Syntax*. Linguistic Inquiry Monographs, Cambridge, MA: MIT Press.
- Kholodilova, M. 2013. Inverse attraction in Ingrian Finnish. *Linguistica Uralica* XLIX:96–116.
- Kholodilova, M. & M. Privizentseva. 2015. Inverse attraction in finno-ugric languages. Talk at ‘Insufficient strength to defend its case’: Case attraction and related phenomena. Wrocław, Poland, September 18–19.
- Kush, D., A. Omaki & N. Hornstein. 2013. Microvariation in islands? In *Experimental syntax and island effect*, eds. J. Sprouse & N. Hornstein, 239–264. Cambridge: Cambridge University Press.
- Lees, R. B. 1960. *The Grammar of English Nominalization*. Mouton, The Hague.
- Lees, R. B. 1961. The Constituent Structure of Noun Phrases. *American Speech* 36:159–168.
- Lehmann, C. 1984. *Der Relativsatz*. Tübingen: Gunter Narr Verlag.
- Lin, J.-W. 2020. Correlatives. In *The Wiley Blackwell Companion to Semantics*, eds. D. Gutzmann, L. Matthewson, C. Maeier, H. Rullmann & a. E. Z. Tho. John Wiley & Sons, Ltd.
- Lipták, A. 2009. The landscape of correlatives: An empirical and analytical survey. In *Correlatives cross-linguistically*, ed. A. Lipták, 1–49. Amsterdam: John Benjamins.
- Matushansky, O. 2004. Going through a phase. In *Perspectives on phases*, eds. M. McGinnis & N. Richards, 157–181. MIT Working Papers in Linguistics 49, Cambridge: MIT, MIT Working Papers in Linguistics.
- McCawley, J. D. 1981. The syntax and semantics of English relative clauses. *Lingua* 53:99–149.
- McCawley, J. D. 1998. *The Syntactic Phenomena of English*. Chicago, London: The University of Chicago Press.
- Merchant, J. 2006. Polyvalent case, geometric hierarchies, and split ergativity. In *Proceedings of the 42nd annual meeting of the Chicago Linguistics Society*, volume 2, eds. J. Bunting, S. Desai, R. Peachey, C. Straughn & Z. Tomkova, 57–76. Chicago: Chicago Linguistic Society.

- Miyagawa, S. 2001. The EPP, Scrambling, and Wh-in-Situ. In *Ken Hale: A Life in Language*, ed. M. Kenstowicz, 293–338. Cambridge, MA: MIT Press.
- Munn, A. 1994. A Minimalist account of reconstruction asymmetries. *North East Linguistics Society* 24:397–410.
- Murphy, A. & Z. Puškar. 2018. Closest conjunct agreement is an illusion. *Natural Language & Linguistic Theory* 36:1207–1261.
- Ott, D. 2012. *Split Topicalization and Quantifier Float in German*. Amsterdam: John Benjamins.
- Ott, D. 2015. Symmetric merge and local instability: Evidence from split topics. *Syntax* 18:157–200.
- Pankau, A. 2018. The Matching Analysis of relative clauses: an argument from antipronominal contexts. *The Journal of Comparative Germanic Linguistics* 21:189–245.
- Partee, B. 1975. Montague Grammar and Transformational Grammar. *Linguistic Inquiry* 6:203–300.
- Partee, B. 2015. Lecture 10. Relative clauses. Handout for the class “Current Issues in Formal Semantics” at MGU, Moscow, May 17, 2005.
- Pittner, K. 1995. The case of German relatives. *The Linguistic Review* 12:197–232.
- Platzack, C. 2000. A Complement-of-N⁰ Account of Restrictive and Non-Restrictive Relatives: The case of Swedish. In *The syntax of relative clauses*, volume 32 of *Linguistik aktuell / Linguistics today*, eds. A. Alexiadou, P. Law, A. Meinunger & C. Wilder, 265–308. Amsterdam, Philadelphia: John Benjamins.
- Potsdam, E. 2006. Backward object control in Malagasy: Against an empty category analysis. In *The Proceedings of the 25th West Coast Conference on Formal Linguistics*, eds. D. Baumer, D. Montero & M. Scanlon, 328–336. Somerville: Cascadilla Press.
- Ross, J. R. 1967. Constraints on variables in syntax. Doctoral thesis, Massachusetts Institute of Technology, Cambridge, MA.
- Salzmann, M. 2006. Resumptive Prolepsis: A Study in indirect A'-dependencies. Doctoral thesis, Universiteit Leiden.
- Salzmann, M. 2017. *Reconstruction and Resumption in Indirect A'-dependencies. On the Syntax of Prolepsis and Relativization in (Swiss) German and beyond*. Berlin, Boston: Mouton De Gruyter.
- Salzmann, M. 2018. A new version of the Matching Analysis. Combining deletion under recoverability with vehicle change. In *Reconstruction effects in relative clauses*, volume 75 of *Studia grammatica*, eds. M. Krifka & M. Schenner, 187–223. Berlin: Mouton De Gruyter.
- Sauerland, U. 1998. On the Making and Meaning of Chains. Doctoral thesis, Massachusetts Institute of Technology, Cambridge, MA.
- Sauerland, U. 2003. Unpronounced heads in relative clauses. In *The Interfaces: Deriving and interpreting omitted structures*, volume 61 of *Linguistik aktuell / Linguistics today*, eds. K. Schwabe & S. Winkler, 205–226. Amsterdam, Philadelphia: John Benjamins.
- Schachter, P. 1973. Focus and relativization. *Language* 49:19–46.
- Sichel, I. 2018. Anatomy of a Counterexample: Extraction from Relative Clauses. *Linguistic Inquiry* 49:335–378.
- Sportiche, D. 2017. Relative Clauses. Ms., University of California, Los Angeles.
- Srivastav, V. 1991. The syntax and semantics of correlatives. *Natural Language & Linguistic Theory* 9:637–686.
- Stabler, E. P. 1997. Derivational minimalism. In *Logical aspects of computational linguistics*, ed. C. Retoré, 68–95. Berlin: Springer.
- Svenonius, P. 2004. On the edge. In *Peripheries: Syntactic edges and their effects*, eds. D. Adger, C. de Cat & G. Tsoulas, 261–287. Dordrecht: Kluwer.
- Takahashi, S. & S. Hulsey. 2009. Wholesale Late Merger: Beyond the A/ \bar{A} distinction. *Linguistic Inquiry* 40:387–426.
- Toldova, S. J. & T. A. Shalganova. 2018. Reflexive [refleksiv]. In *Èlementy mokšanskogo jazyka v tipologičeskom osveščennii [Elements of Moksha language in the typological perspective]*, eds. S. J. Toldova & M. A. Kholodilova, 633–655. Moscow: Buki Vedi.
- Touratier, C. 1980. *La relative. Essai de théorie syntaxique (à partir de faits latins, français, allemands, anglais, grecs, hébreux, etc.)*. Paris: Klincksieck.
- Vergnaud, J.-R. 1974. French relative clauses. Doctoral thesis, Massachusetts Institute of Technology, Cambridge, MA.
- Vincent, J. W. 2021. Extraction from relative clauses: An experimental investigation into variable island effects in English—or—this is a dissertation that we really needed to find someone who'd write. Doctoral thesis, University of California Santa Cruz, Santa Cruz.
- de Vries, M. 2002. The Syntax of Relativization. Doctoral thesis, University of Amsterdam.
- Watanabe, A. 2004. Parametrization of quantificational determiners and head-internal relatives. *Language and Linguistics* 5:59–97.
- Wood, J., E. F. Sigurðsson & I. E. Nowenstein. 2017. Inverse attraction in Icelandic relative clauses. In *Syntactic Variation in Insular Scandinavian*, volume 1 of *Studies in Germanic Linguistics*, eds. H. Thráinsson, C. Heycock, H. P. Petersen & Z. S. Hansen, 200–232. Amsterdam, Philadelphia: John Benjamins.
- Wurmbrand, S. 2012. The syntax of valuation in auxiliary-participle constructions. In *Proceedings of the 29th West Coast Conference on Formal Linguistics (WCCFL 29)*, eds. J. Choi, E. A. Hogue, J. Punske, D. Tat, J. Schertz & A. Trueman, 154–162. Somerville: Cascadilla Press.
- Zeijlstra, H. 2012. There is only one way to agree. *The Linguistic Review* 29:491–539.

Appendices

A: Against DP in Spec,XP: Category, scope, and c-command

- Since the problems for the relative clause structure in (14) come from the D-N relation, it seems that they might be resolved by including the D head into the noun phrase in Spec,XP.

(94) DP in Spec,XP

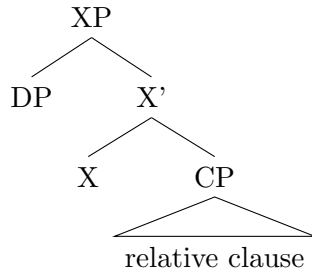

- This structure is also problematic in various respects.
 1. As shown by Partee (1975, 2015), determiners and quantifiers must scope over both the head noun and the relative CP under the restrictive interpretation.
 2. XP is the topmost projection in (94), so it determines the category and the distribution of the phrase. This predicts that the distribution of a noun plus a relative clause differs from the distribution of regular noun phrases.
 3. The whole noun phrase is in the specifier of X in (94) and hence does not c-command the material in the main clause. C-command is though required for anaphor binding

(95) NOM ← GEN

Pet'ε-n'i [kona-n' tona-ft-in'ə ard-əma] mi-z'ə es'i mašinə-nc.
 Petja-GEN which-GEN teach-PST.3.O.1SG.S drive-NZR sell-PST.3SG.O.3SG.S self car-3SG.POSS.SG.GEN
 'Petja_i whom I taught to drive sold his_i car.'

B: Appositive interpretation

- I would like to suggest that the the raising derivation can be reconciled with the appositive interpretation if it is the DP rather than the NP that moves out of the relative clause.

(96) Relative DP

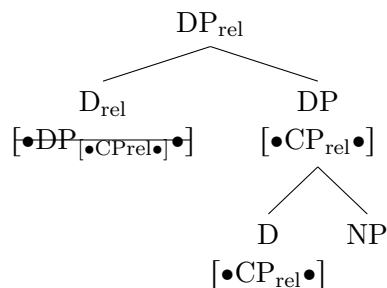

(97) Merge of the head DP

